

Termo Eléctrico para Agua Caliente • 100 a 250 litros

De Pie, 0.6 Mpa con calefactor de 2,2kW con flange.
De Pie, 0.6 Mpa con calefactor de 3-6kW con flange.

OKCE 100 S/2,2kW
OKCE 125 S/2,2kW

OKCE 160 S/2,2kW,
OKCE 160 S/3-6kW
OKCE 200 S/2,2kW,
OKCE 200 S/3-6kW
OKCE 250 S/2,2kW,
OKCE 250 S/3-6kW

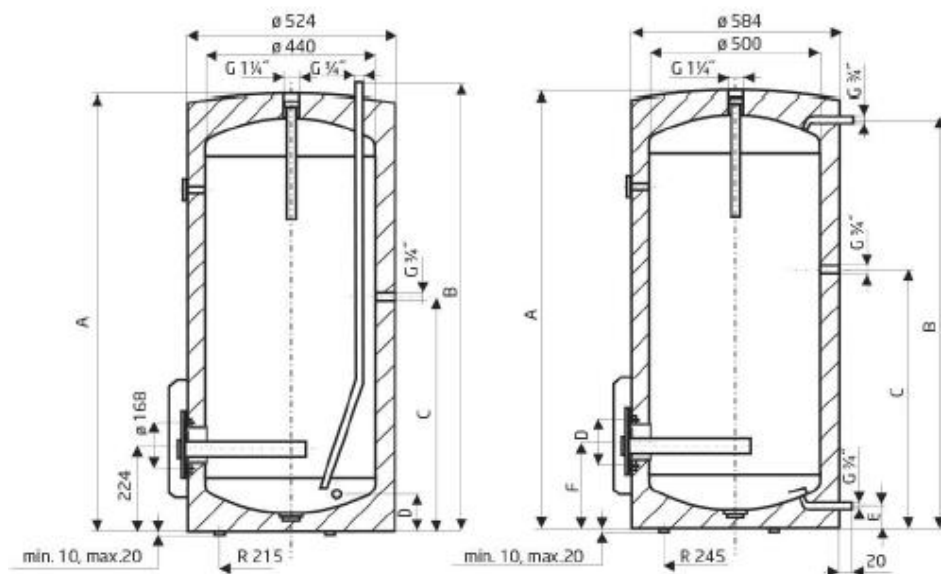

Tipo	A	B	C	D
OKCE 100 S/2.2 kW	815	865	517	116
OKCE 125 S/2.2 kW	980	1034	517	116

Tipo	A	B	C	D	E	F
OKCE 160 S/2.2 kW	1018	952	509	168	65	248
OKCE 200 S/2.2 kW	1328	1264	844	168	65	248
OKCE 250 S/2.2 kW	1508	1448	1048	168	68	248

Tipo	A	B	C	D	E	F
OKCE 160 S/3-6 kW	1018	952	509	210	65	280
OKCE 200 S/3-6 kW	1328	1264	844	210	65	280
OKCE 250 S/3-6 kW	1508	1448	1048	210	68	280

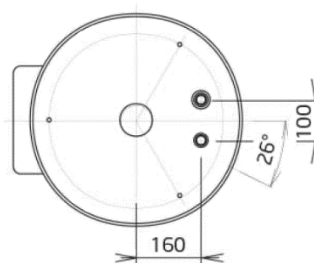

Modelos
100 S/2.2 kW
125 S/2.2 kW
160 S/2.2 kW
200 S/2.2 kW
250 S/2.2 kW
160 S/3-6 kW
200 S/3-6 kW
250 S/3-6 kW

Tipo	OKCE 100 S/2.2 kW	OKCE 125 S/2.2 kW	OKCE 160 S/2.2 kW	OKCE 200 S/2.2 kW/3-6 kW	OKCE 250 S/2.2 kW/3-6 kW
Volumen (litros)	100	125	160	200	250
Peso en kg	44	52	60/66	76/82	86/92
Presión máxima de trabajo en MPa	0.6	0.6	0.6	0.6	0.6
Temperatura Máxima HUW	80	80	80	80	80
Tiempo de Calentamiento de 10°C a 60°C (hr)	3	3.5	4.5/3.2-1.6	5.5/4.2	7/5-2.5
Voltage (V/Hz)	1 PE-N-230/50	1 PE-N-230/50	1 PE-N-230/50	1 PE-N-230/50	1 PE-N-230/50
Voltage (V/Hz)	-	-	3 PE-N-400/50	3 PE-N-400/50	3 PE-N-400/50
Protección Eléctrica	IP 44	IP 44	IP 44	IP 44	IP 44
Pérdidas de calor (kWh/24h)		0.88/C	1.09/C	1.39/C	1.4/B 1.72/B